

QMMF
الاتحاد القطري للسيارات والدراجات النارية
QATAR MOTOR & MOTORCYCLE FEDERATION



رالي قطر الدولي
Qatar International Rally

FIA
MIDDLE EAST
RALLY
CHAMPIONSHIP



16TH - 18TH FEBRUARY 2023
RALLY GUIDE

وزارة الرياضة والشباب
Ministry of Sports and Youth
وزارة قطر
State of Qatar



AL MAHA
ISLAND LUSAIL



@QMMF_official



@qmmf_official



qmmf_official



QATAR MOTOR & MOTORCYCLE FEDERATION



QMMF TV

www.qmmf.com

Table of contents

Page Title	Page No.
President Welcome Speech	03
QJR Introduction & QMMF History	04
Past Winners 1983 – 2022	05
Organizers Contact Details	07
Qatar International Rally Key Officials	08
Rally Program Schedule	10
Service Park(s) and Remote Service Zones if applicable	11
Fuel – Refuelling & Tyres	12
Scrutineering, Sealing & Marking	13
Staring & Finishing Procedures	15
Passes & Plates Stickers Sample	17
Passes & Plates Motor Stickers Guide	18
Appendix 1 – Itinerary [1 & 2] + Compared with pervious years	19
Appendix 2 – Reconnaissance	22
Appendix 5 – Drivers Equip / Extract FIA ISC Appendix L	24
Appendix 7 – Services Park Area Layout Plan	26
Appendix 8 – Routes Maps	27
QMMF Media & Media Coverage	30
Appendix 9 – Odometer Calibration	31
Appendix 9 – Al Maha Island (Holding Area)	33
Appendix 11 – Remote Refuelling Access	37
Service Park Facilities Order & Service Area Request Form	42
Reconnaissance Registration Form	43
On-Board Camera Request Form	44
Authorisation Form	45
Rule’s State of Qatar	46
Useful Facts About Qatar	47
Qatar Cultural Awareness	48
Medical & Safety Services	49
Network & Transportation Services	50
Import of Vehicles, Spare Parts & Shipping	51
Carson Logistics Contact & Bank Details	53
Hospitality, Accommodation & Hotels	54
Appendix 12 – Travel Way from the Airport to LCSC	56



President welcome speech



I would like to take this opportunity to extend a warm welcome to all our competitors, teams, officials and members of the media to the Qatar International Rally, which will be the second round of the 2023 FIA Middle East Rally Championship (MERC).

The State of Qatar has received global attention in recent weeks through the FIFA World Cup Qatar 2022 and the event put on by the Qatar Motor and Motorcycle Federation (QMMF) will be one of the first to be held in Qatar after the successful football tournament that we were all very proud to witness.

Our team at the QMMF has considerable experience of organising international events and we are looking forward to hosting a challenging round of the MERC once again. The regional rally series has been an integral part of the FIA motor sporting calendar since 1984 and we have seen many exciting moments over the course of all those years.

We are looking forward to hosting what we hope will be another safe and successful event in February and look ahead to welcoming you all again.

Sincerely Yours,

Abdulrahman Al-Mannai
President of QMMF.



QMMF & QIR



Qatar Motor & Motorcycle Federation

Qatar Motor and Motorcycle Federation was founded on 21st July 1987. The current President of the organization is Mr. Abdul Rahman bin Abdul Latif Al Mannai. It is a non-profit government organization and is the sole motorsport authority in the State of Qatar.

Its main purpose is to promote motorsport in Qatar and Middle East always with safety, healthy and fairness. We are focused on helping the young drivers and riders to develop their skills and passion in motorsport.

Qatar International Rally

This rally will be run in compliance with the FIA International Sporting Code (ISC) including appendices, the FIA Regional Rally Sporting Regulations including appendices, the ASN Rally Regulations (only when related to national cars) the WADA/NADA Codes, and the FIA Anti-Doping Regulations, as amended from time to time. The National Road Traffic Regulations shall apply. Unless provided otherwise by these Supplementary Regulations, the provisions of the above Rules and Regulations shall apply.

Any modifications, amendments and/or additions to the Rules and Regulations shall be made in the form of numbered and dated bulletins.

Additional information will be published in the Rally Guide.

All FIA regulations can be found at <https://www.fia.com/regulations> .



رالي قطر الدولي
Qatar International Rally



الاتحاد القطري للسيارات والدراجات النارية
QATAR MOTOR & MOTORCYCLE FEDERATION

Past winners 1983 - 2022

1983



Driver: Saeed Al-Hajri
Co-Driver: John Spiller
Motor Model: Opel Ascona 400

1984



Driver: Saeed Al-Hajri
Co-Driver: John Spiller
Motor Model: Porsche 911 SC RS

1985



Driver: Saeed Al-Hajri
Co-Driver: John Spiller
Motor Model: Porsche 911 SC RS

1986



Driver: Björn Waldegård
Co-Driver: Fred Gallagher
Motor Model: Toyota Celica Twincam Turbo

1987



Driver: Saeed Al-Hajri
Co-Driver: John Spiller
Motor Model: Porsche 911 SC RS

1988



Driver: Muhammed Bin Sulayem
Co-Driver: Ronan Morgan
Motor Model: Toyota Celica Twincam Turbo

1989



Driver: Saeed Al-Hajri
Co-Driver: Steve Bond
Motor Model: Ford Sierra RS Cosworth

1990



Driver: Muhammed Bin Sulayem
Co-Driver: Ronan Morgan
Motor Model: Toyota Celica GT-4 (S165)

1991



Driver: Muhammed Bin Sulayem
Co-Driver: Ronan Morgan
Motor Model: Toyota Celica GT-4 (S165)

1992



Driver: Saeed Al-Hajri
Co-Driver: Mike Corner
Motor Model: Toyota Celica GT-4 (S165)

1993



Driver: Nasser Khalifa Al-Attiyah
Co-Driver: Mubarak Al-Hajri
Motor Model: Toyota Celica GT-4 (S165)

1994



Driver: Suhail Al-Maktoum
Co-Driver: Mubarak Al-Hajri
Motor Model: Toyota Celica GT-4

1995



Driver: Nasser Khalifa Al-Motawi
Co-Driver: Mubarak Al-Hajri
Motor Model: Toyota Celica GT-4

1996



Driver: Muhammed Bin Sulayem
Co-Driver: Ronan Morgan
Motor Model: Ford Escort RS Cosworth

1997



Driver: Muhammed Bin Sulayem
Co-Driver: Ronan Morgan
Motor Model: Ford Escort WRC

1998



Driver: Muhammed Bin Sulayem
Co-Driver: Ronan Morgan
Motor Model: Ford Escort WRC

1999



Driver: Nizar Al-Shanfari
Co-Driver: Tom Steele
Motor Model: Mitsubishi Lancer Evo V

2000



Driver: Muhammed Bin Sulayem
Co-Driver: Ronan Morgan
Motor Model: Ford Focus RS WRC 99

2001



Driver: Muhammed Bin Sulayem
Co-Driver: Khaled Zakharia
Motor Model: Ford Focus RS WRC 99

2002



Driver: Muhammed Bin Sulayem
Co-Driver: Ronan Morgan
Motor Model: Ford Focus RS WRC 00

2003



Driver: Nasser Al-Attiyah
Co-Driver: Steve Lancaster
Motor Model: Subaru Impreza S8 WRC'02

2004



Driver: Nasser Al-Attiyah
Co-Driver: Chris Patterson
Motor Model: Subaru Impreza STi

2005



Driver: Nasser Al-Attiyah
Co-Driver: Chris Patterson
Motor Model: Subaru Impreza WRX

2006



Driver: Nasser Al-Attiyah
Co-Driver: Chris Patterson
Motor Model: Subaru Impreza STi

Past winners 1983 - 2022

2007



Driver: Nasser Al-Attiyah
Co-Driver: Chris Patterson
Motor Model: Subaru Impreza STi

2008



Driver: Nasser Al-Attiyah
Co-Driver: Chris Patterson
Motor Model: Subaru Impreza STi

2009



Driver: Nasser Al-Attiyah
Co-Driver: Chris Patterson
Motor Model: Mitsubishi Lancer Evo X

2010



Driver: Nasser Al-Attiyah
Co-Driver: Giovanni Bernacchini
Motor Model: Ford Fiesta S2000

2011



Driver: Nasser Al-Attiyah
Co-Driver: Giovanni Bernacchini
Motor Model: Ford Fiesta S2000

2012



Driver: Abdulaziz Al-Kuwari
Co-Driver: Nasser Al-Kuwari
Motor Model: Mini Cooper S2000 1.6T

2013



Driver: Nasser Al-Attiyah
Co-Driver: Giovanni Bernacchini
Motor Model: Ford Fiesta RRC

2014



Driver: Nasser Al-Attiyah
Co-Driver: Giovanni Bernacchini
Motor Model: Ford Fiesta RRC

2015



Driver: Nasser Al-Attiyah
Co-Driver: Mathieu Baumel
Motor Model: Ford Fiesta RRC

2016



Driver: Nasser Al-Attiyah
Co-Driver: Mathieu Baumel
Motor Model: Skoda Fabia R5

2017



Driver: Rashid Al-Naimi
Co-Driver: Hugo Magalhães
Motor Model: Subaru WRX STi

2018



Driver: Vojtech Staff
Co-Driver: Veronica Havelkova
Motor Model: Skoda Fabia R5

2019



Driver: Nasser Al-Attiyah
Co-Driver: Mathieu Baumel
Motor Model: Volkswagen Polo GTI

2021



Driver: Nasser Al-Attiyah
Co-Driver: Mathieu Baumel
Motor Model: Volkswagen Polo GTI

2022



Driver: Nasser Al-Attiyah
Co-Driver: Mathieu Baumel
Motor Model: Volkswagen Polo GTI

2023



رالي قطر الدولي
Qatar International Rally



رالي قطر الدولي
Qatar International Rally



الاتحاد القطري للسيارات والدراجات النارية
QATAR MOTOR & MOTORCYCLE FEDERATION

Organizers Contact Details

Rally HQ Contact Details

Al Wusail, North Relief Road PO Box 8708
Lusail Sports Arena
Doha - Qatar

+974 443 79 885

www.qmmf.com

info@qmmf.com.qa

+974 443 79 732

For Media Inquiries Contact

Abdulaziz Al-yafie

Mansour Chebli

+974 550 48 482

+974 339 30 440

Abdulaziz@qmmf.com.qa

Manshebly@hotmail.com

QMMF Official Social Media Accounts

@qmmf_official

@qmmftv



Digital Notice Board

APP: **Sportity** Password: **QIR2023**

Qatar International Rally Key Officials

Organization Committee

Chairman



**Abdulrahman
Al Mannai**
President

Member



**Abdulrazaq
Al Kuwari**
General Secretary

Member



**Amro
Al Hamad**
Executive Director

Stewards of the Meeting

Chairman

FIA Steward

ASN Steward

Secretary to the Stewards

Imad Lahoud

Ediz Atabey

Amro Al-Hamad

Lydia Labaki

FIA Delegates & Observer

FIA Observer

FIA Technical Delegate

FIA Safety Delegate

Ediz Atabey

Karmo Uusmaa

Rashid Al balushi



Qatar International Rally Key Officials

Senior Officials

Clerk of the Course	Pedro Almeida
Deputy Clerk of the Course	Rashid Al-Sulaiti
Chief Safety Officer	Dexter Celemen
Deputy Chief Safety Officer	Zia Rehman
Chief Medical Officer	Dr. Amr Aboulwafa
Competitors Relations Officer	David Patterson
Chief Scrutineer	Stanley da Silva
Service Park Coordinator	Pierre Arries
Security Officer	Karl Heinz
Stage Commanders	Nasir Khan
	Mohammed Akram
	Zakir Ullah
Results Coordinator	Wolfgang Schindale
Secretary of the Meeting	Angelene Lapuz
Media Relations Officer	Neil Perkins
Local Media Relations Officer	Mansour Chebly



Rally Program Schedule

Thursday, 22 December		
	Publishing of the supplementary regulations	Website
	Entries open	
Thursday, 19 January		
17.00h	1 st Closure date of entries (see SR art. 4.4.2)	Rally Office
Thursday, 26 January		
	Issuing of the rally guide	Website
Thursday, 02 February		
17.00h	Final closure date of entries (see SR art. 4.4.2)	Rally Office
Monday, 06 February		
17.00h	Closing date for order of extra services in SP	Rally Office
Thursday, 09 February		
17.00h	Publication date of entry list	Digital Notice Board
Tuesday, 14 February		
16.00 / 20.00h	Reconnaissance registration (*)	QMMF Office
	Administrative checks (*)	
	Collection of materials and documents	
	Collection of reconnaissance GPS trackers	
Wednesday, 15 February		
15.00h	Reconnaissance (see article 9 and Appendix 2)	QMMF Office
	Opening of Media Centre	
18.00 / 20.00h	Scrutineering, components sealing & marking (*)	
Thursday, 16 February		
07.00 / 12.00h	Scrutineering, components sealing & marking (*)	Lusail Sports Arena
	Return of reconnaissance cards & GPS trackers	
08.00 / 11.00h	Collection of rally safety tracking systems	Digital Notice Board
<i>tba</i>	Re-scrutineering	
12.00h	Drivers briefing	
15.00 / 17.00h	Reconnaissance of SSS 1 (on foot)	Karting Academy
16.00h	Publication of list of cars eligible to start	Digital Notice Board
	Publication of the start list for Leg 1 / Section 1	
	Publication of the start list for Leg 1 / Section 2	
17.30 / 18.00 h	Cars enter pre-start holding area	Al Maha Island
18.30h	Pre-rally press conference	
19.00h	Rally start	
20.00h	SSS1 - Super special stage	Lusail Sports Arena
20.10h	Finish of section 1 (estimated time for 1 st car)	
Friday, 17 February		
09.00h	Start of leg 1 Section 2	Lusail Sports Arena
15.00h	Finish of leg 1 (estimated time for 1 st car)	
17.00h	Publication of the start list for leg 2	Digital Notice Board
18.30h	All cars must be returned to Parc Fermé from the 45' flexi service	Lusail Sports Arena
	Re-scrutineering, cars to re-start after retirement	
Saturday, 18 February		
07.30h	Start of leg 2	Lusail Sports Arena
15.03h	Finish of the rally (estimated time for 1 st car)	
	Final scrutineering	
17.00h	Publication of the provisional classification	Digital Notice Board
18.30h	Post-rally press conference	Al Maha Island
19.00h	Podium ceremony / Prize-giving	

(*) Schedule to be published in a bulletin



Service Park(s) and Remote Service Zones if applicable

Coordinator contact



Pierre Arries - QMMF



+974 311 56 228



parries@qmmf.com.qa

Service park location



Lusail Sports Arena

25° 28.956'N 51° 27.482'E

Access to the service park

Only duly accredited vehicles with the plates provided by the organization will be allowed to access to the service park.

Facilities at service park



Medical Facility



General Security



Wifi Service



General lighting in the [Whole Bivouac]



Toilets
[Male, Female]



Waste Containers



Car washing Area
[outside of the service park area]

Two-way radios

2-Way radios are permitted to operate only on government controlled and designated frequencies.

Customs

competitors are responsible for clearing their own cars and spare parts through customs. Where possible, assistance may be given. However, at least 14 days' notice should be given if any assistance is required.

Visas

Visas to enter Qatar are required for several nationalities. Competitors requiring assistance in obtaining a visa must give at least 21 days' notice prior to their day arrival. Assistance cannot be guaranteed if this notice is not received in time.



Fuel - Refuelling & Tyres

Fuel - Refuelling

As per articles 61 and 62 of FIA RRSR.

All type of fuel must follow Appendix J Art. 252.9. (RRSR V3 Art. 62).

It is forbidden to refuel inside the Service Park.

Official refuel zones will be located at the exit of the service park and at a remote location on the rally route indicated in the rally itinerary and in the road book.

With reference to FIA RRSR art. 61.3, for each leg one commercial filling station was designated by the organiser to be used by the competitors for refuelling along the rally route. The exact location of these commercial filling stations is indicated in the supplementary regulations.

Tyres - Wheels

As per article 13 of FIA RRSR and variant V3.

In addition to complying with the FIA RRSR, the following quantities of tyres are confirmed for use during the rally:

Type of car	Max no. of tyres
RC2 / RGT cars	18
RC3 / RC4 / RC5 / Other cars	14

A wheel/tyre marking / barcode reading zone may be established at the exit of the authorised service parks. For the sole purpose of assisting the tyre marking procedure, one team member for each crew may access this zone.

A tyre mark checking zone may be established at the entrance of the authorised service parks.





Scrutineering, Sealing & Marking

Scrutineering, venue & time

Cars may be presented at scrutineering by a representative of the team.

See programme (SR Art. 3). A detailed schedule will be published by means of a bulletin.

Any delay on the presentation at the time control installed at the entrance of the holding area will result in the following penalties:

from 1 to 15 minutes	€ 100
from 16 to 30 minutes	€ 150
> 30 minutes	€ 200
> 60 minutes	Start may be denied

Cars must be presented at scrutineering with the competition numbers, rally plates and all advertising (compulsory and optional) affixed.

Scrutineering mandatory documents

- Cars' complete certified homologation
- SOS / OK board (DIN A3 format)

For each car of the FIA Priority Drivers, one spare gearbox and one set of spare differentials (front and/or centre and/or rear) may be used in each rally. These spare components and those fitted to the car will be marked/sealed at initial scrutineering. These cars must have their sump guards removed for sealing of gearboxes and differentials and be kept with the car for the purpose of weighting.

The installation of the tracking system will be checked at scrutineering.

On-board camera positions and mountings (see SRs art. 12.12) will be checked at scrutineering.



Scrutineering, Sealing & Marking

Mud flaps

See ISC Appendix J, Article 252.7.7.

Windows

See ISC Appendix J, Article 253.11.

Driver's safety equipment

All items of clothing including helmets and FHR (Front Head Restraint) intended to be used, e.g. HANS devices, must be presented for scrutineering. They shall be checked for compliance with Appendix L, Chapter III.

Noise Level

N/A

Special National Requirements

N/A

Installation of safety tracking equipment

For every vehicle, it is mandatory to mount a tracking system, live satellite tracking, data recording and emergency signalling device that will be used to monitor the position, movement and status of all competing cars at all times during the rally. This apparatus will be provided by the organiser.

The installation of the provided tracking system will be checked at scrutineering.

Any misuse of the system(s) during the rally will result in the competitor being reported to the Stewards who may impose penalties which may go as far as exclusion.





Start & Finish Procedures

Rally Start

The official start of the rally will be at TC0

(Al Maha Island)



Image 01: A Maha Island, Lusail.

Cars must be driven by one of the drivers or a team representative to the pre-start holding area, where they will enter between **17.30h and 18.00h**.

- ◆ Any delay on the presentation at the time control installed at the entrance of the holding area will result in the following penalties:

from 1 to 15 minutes	€ 100
from 16 to 30 minutes	€ 150
> 30 minutes	€ 200
> 60 minutes	Start may be denied

The holding area will be under vigilance. Access to the holding area is limited to team members and media representatives with appropriate identification.

No service will be allowed inside the holding area.



Start & Finish Procedures

Finish Procedures

The competitive element of the rally will conclude at TC13C. From this point, all cars are subject to Parc Fermé rules until the Parc Fermé is opened at the instruction of the stewards.

Competitors are reminded that attendance at the finish ceremony and prize giving is compulsory for all classified crews and crew members must wear their approved overalls.

In the event a car is not driveable for the above procedure, this must be reported to the clerk of the course and the crew members concerned must still attend the podium finish ceremony.

Immediately after the publication of the Final Classification and opening of the Parc Fermé a convoy will be organized for all classified rally cars from the Service Park to the location of the Prize Giving (Al Maha Island). Cars may be driven by the crew or by one team member.

Post-event Press Conference (for invited drivers only) will take place at 18.30h.

Prize Giving Ceremony will start at 19.00h. Cars will pass by the ramp in reverse order of the final classification.

After the conclusion of the ceremony cars will be released and may be driven back to the service park.





رالي قطر الدولي
Qatar International Rally



الاتحاد القطري للسيارات والدراجات النارية
QATAR MOTOR & MOTORCYCLE FEDERATION

Passes & Plates Stickers Sample

Stickers Sample Guide



To be affixed on the rear window, to the service area with close pedestrian access to the service area.



To be affixed on the front, centered on the bonnet of the vehicle and will have 1 piece per entered competitor. this plate will allow the cars to be parked in close proximity to the service area with close pedestrian access.





To be affixed on the front, centered on the bonnet of the vehicle and each entered competitor will be allowed 2 service vehicles. This plate will allow the vehicle in the service park.



Passes & Plates Motor Stickers Guide

Decals and Positioning of Supplementary Advertising

Obligatory organiser's advertising: Qatar International Rally / QMMF	<u>Yellow stickers</u> (see FIA RRSR art. 27 to 29)	
Additional organiser's advertising: QMMF	<u>Green stickers:</u> Two 67x17 cm stickers (front door panels) Two 20x12 cm stickers (windscreen upper corners)	





Appendix 1 - Itinerary (1)

Leg 1 (Thursday)					16.02.2022	
TC	LOCATION	SS dist.	Liaison dist.	Total dist.	Target time	
START Leg 1						
Al Maha Island						
0	Rally Start		0,0	0,0	19:00	
1	LCSC Karting Academy		15,74	15,74	00:25	19:25
SS1	LCSC Karting Academy	3,27				20:00
1A*	Parc Fermé IN		1,45	4,72	00:15	20:15
Thursday totals		3,27	17,19	20,46		
* Permitted early check-in						
					Sunrise	06:08
					Sunset	17:28

Section 1

Leg 1 (Friday)					17.02.2022	
TC	LOCATION	SS dist.	Liaison dist.	Total dist.	Target time	
START Leg 1 / Section 2						
Lusail Sports Arena						
1B	Parc Fermé OUT - Service IN		0,0	0,0	09:00	
Service A (Lusail Sports Arena)		3,27	17,19	20,46	00:15	
1C	Service OUT				09:15	
R2	Refuel	0,00	0,00	0,00		
1	Distance to next refuel	48,45	79,69	128,14		
2	Industrial Area		31,19	31,19	00:37	09:52
SS2	Al Khor 1	16,15				09:55
3	Ras Laffan		17,63	33,78	00:37	10:32
SS3	Ras Laffan 1	15,60				10:35
4	Grayyat Al Faida		0,97	16,57	00:22	10:57
SS4	Al Thakhira 1	16,70				11:00
4A	Regroup & Technical Zone IN		29,90	46,60	00:45	11:45
4B	Regroup OUT - Service IN				00:15	12:00
Service B (Lusail Sports Arena)		48,45	79,69	128,14	00:30	
4C	Service OUT				12:30	
R2	Refuel	48,45	79,69	128,14		
2	Distance to next refuel	48,45	79,69	128,14		
5	Industrial Area		31,19	31,19	00:37	13:07
SS5	Al Khor 2	16,15				13:10
6	Ras Laffan		17,63	33,78	00:37	13:47
SS6	Ras Laffan 2	15,60				13:50
7	Grayyat Al Faida		0,97	16,57	00:22	14:12
SS7	Al Thakhira 2	16,70				14:15
7A*	Parc Fermé IN		29,90	46,60	00:45	15:00
7B	Parc Fermé OUT - Flexi Service IN					
Flexi Service C (Lusail Sports Arena)		48,45	79,69	128,14	00:45	
7C*	Flexi Service OUT - Parc Fermé IN				18:30	
All cars must be returned to Parc Fermé no later than						
Friday totals		96,90	159,38	256,28		
* Permitted early check-in						
					Sunrise	06:07
					Sunset	17:28

Section 2

Section 3

Appendix 1 - Itinerary (2)

Leg 2 (Saturday)						18.02.2022
TC	LOCATION	SS dist.	Liaison dist.	Total dist.	Target time	First car due
START Leg 2						
Lusail Sports Arena						
7D	Parc Fermé OUT - Service IN		0,0	0,0		07:30
Service D (Lusail Sports Arena)		0,00	0,00	0,00	00:15	
7E	Service OUT					07:45
RZ	Refuel	48,45	79,69	128,14		
3	Distance to next refuel	30,19	69,94	100,13		
8	Al Mashrab		60,53	60,53	01:00	08:45
SS8	Waab Al Mashrab 1	15,28				08:48
9	Al Waab		3,86	19,14	00:25	09:13
SS9	Al Waab 1	14,91				09:16
	Umm Al Qahab		5,55	20,46		
RZ	Refuel	30,19	69,94	100,13		
4	Distance to next refuel	24,57	44,81	69,38		
10	Umm Al Qahab		6,38	21,29	00:32	09:48
SS10	Umm Birka 1	24,57				09:51
10A	Regroup & Technical Zone IN		43,98	68,55	01:04	10:55
10B	Regroup OUT - Service IN				00:15	11:10
Service E (Lusail Sports Arena)		54,76	114,75	169,51	00:30	
10C	Service OUT					11:40
RZ	Refuel	24,57	44,81	69,38		
5	Distance to next refuel	14,91	0,00	0,00		
11	Al Mashrab		60,53	60,53	01:00	12:40
SS11	Waab Al Mashrab 2	15,28				12:43
12	Al Waab		3,86	19,14	00:25	13:08
SS12	Al Waab 2	14,91				13:11
	Umm Al Qahab		5,55	20,46		
RZ	Refuel	30,19	69,94	100,13		
6	Distance to next refuel	109,52	229,50	339,02		
13	Umm Al Qahab		6,38	21,29	00:32	13:43
SS13	Umm Birka 2	24,57				13:46
13A	Regroup & Technical Zone IN		43,98	68,55	01:04	14:50
13B	Technical Zone OUT - Service IN				00:03	14:53
Service F (Lusail Sports Arena)		54,76	114,75	169,51	00:10	
13C*	Service OUT - Parc Fermé IN					15:03
Saturday totals		109,52	229,50	339,02		
* Permitted early check-in						
						Sunrise 06:06
						Sunset 17:29
TOTALS OF THE RALLY						
	SS	Liaison	Total		%	
Thursday - 1 SS	3,27	17,19	20,46			16,0%
Friday - 6 SS	96,90	159,38	256,28	Special		37,8%
Saturday - 6 SS	109,52	229,50	339,02	Stages		32,3%
Total - 13 SS	209,69	406,07	615,76			34,1%

(v3- 26.01.2023)



Appendix 1 - Itinerary compared with previous years

	2022	2023	2023/2022
No. of Legs	2	2	=
No. of Sections	4	5	+ 1
No. of Special Stages	12	13	+ 1 (SSS)
Total distance of itinerary	643,70 km	618,52 km	- 3,91%
Overall length of Special Stages	212,00 km	209,69 km	- 1,09%
% of Special Stages	32,93%	33,90%	+ 2,95%
New Special Stages (2)		SSS 1 SS 8/11	
Revised Special Stages (2)		SS 3/6 SS 4/7	
Similar Special Stages (3)		SS 2/5 SS 9/12 SS 10/13	





Appendix 2 - Reconnaissance

Reconnaissance will take place according to the following schedule:

SS 8-11 / SS 9-12 / SS 10-13	15 February – from 07.00h to 15.00h
SS 3-6 / SS 4-7 / SS 2-5	15 February – from 12.00h to 18.00h
SSS 1	16 February – from 15.00h to 17.00h (exclusively on foot)



Registration

As per article 35 of FIA RRSR and variant V3.

Reconnaissance registration will take place at QMMF office according to the rally program. A reconnaissance registration form must be completed before commencing reconnaissance. The crews must register in person.

Competitors will be issued with three reconnaissance numbers (that must be fixed to the top right corner of the windscreen & rear side windows) and one rear windscreen plate.

Rally cars used in the event may not be used for reconnaissance.

A reconnaissance record card will be supplied which must be carried in the car for the duration of the reconnaissance. This card will be stamped appropriately recording every run on each special stage. This procedure will not apply for the reconnaissance of SSS1.

Reconnaissance record cards must be returned to the Rally Office according to the program.





Appendix 2 - Reconnaissance

Specific regulations

- During reconnaissance, all national traffic regulation must be followed, including but not limited to the speed limits. Please note that the Special Stages will not be closed to public traffic during reconnaissance.
- Unless a lower limit is indicated by traffic signs or by written instructions in the road book or in a bulletin, the maximum speed on special stages during reconnaissance is 90 kph.
- Reconnaissance of the super special stage is allowed only on foot during the period mentioned in the programme, without limitation of the number of passages.

Collection / return of speed control checking devices

All reconnaissance cars must be equipped with a speed control checking device that will be available at the Rally Office during reconnaissance registration. The equipment must be returned to the Rally Office together with the reconnaissance record cards according to the rally program.





Appendix 5 - Drivers Equipment / Extract from FIA ISC APPENDIX L

Helmets (Appendix L, Chapter III, Art.1)

All drivers and co-drivers must wear crash helmets homologated to one of the following FIA standards:

- 8858-2002 or 8858-2010 (Technical List N°41),
- 8859-2015 (Technical List N°49),
- 8860-2004 or 8860-2010 (Technical List N°33), or
- 8860-2018 or 8860-2018-ABP (Technical List N°69)

Frontal Head Restraint (FHR, Appendix L, Chapter III, Art.3)

All drivers and co-drivers must use FIA approved FHR systems homologated to FIA standard 8858.

Approved FHRs, anchorages and tethers are listed in Technical List N° 29.

See also helmet compatibility chart in Appendix L, Chapter III, Art. 3.3.

Flame-resistant clothing (Appendix L, Chapter III, Art.2)

All drivers and co-drivers must wear overalls as well as gloves (optional for co-drivers), long underwear, a balaclava, socks and shoes homologated to the FIA 8856-2000 standard (Technical List N°27) or 8856-2018 (Technical List N° 74).

Please pay special attention to the prescriptions of Art. 2 concerning embroidery and printing on flame-resistant clothing (manufacturer certificates etc.) as well as concerning the correct wearing of the clothing elements!

See also Regional Rally Sporting Regulations, Article 53.1.





Appendix 5 - Drivers Equipment / Extract from FIA ISC APPENDIX L

Biometric Devices (Appendix L, Chapter III, Art.2.1)

Drivers may wear a device to collect biometric data during racing.

- If the biometric device is integrated into a protective garment homologated to FIA Standard 8856, the garment shall be homologated to FIA Standards 8856 and 8868-2018.
- If the biometric device is a stand-alone device, then the device must be homologated to FIA Standard 8868-2018 only. This device must be worn in addition to the garment homologated to FIA Standard 8856.

Wearing of jewellery (Appendix L, Chapter III, Art.5)

The wearing of jewellery in the form of body piercing or metal neck chains is prohibited during the competition and may therefore be checked before the start.

RELATED LINKS:

FIA International Sporting Code and appendices: <https://www.fia.com/regulation/category/123>

FIA Technical Lists: <https://www.fia.com/regulation/category/761>



Appendix 7 - Service Park Area Layout Plan

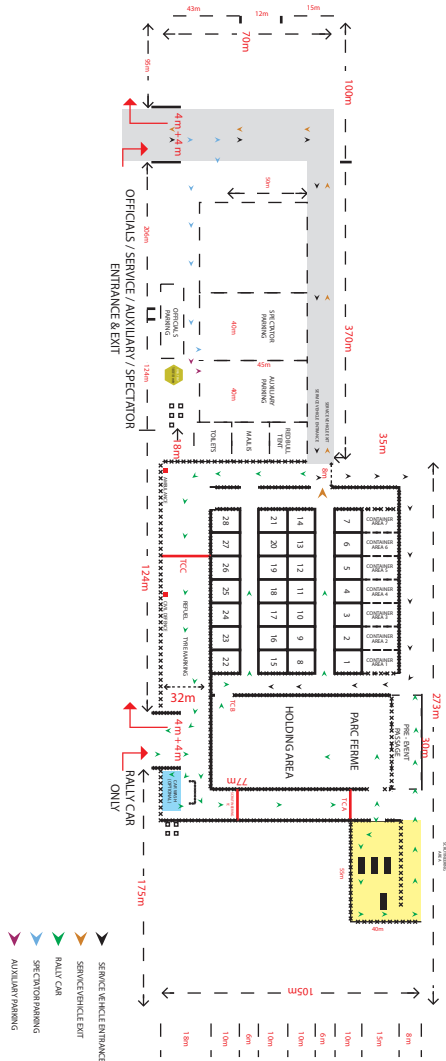



Appendix 8 - Thursday Route Map



Appendix 8 - Friday Route Map





Appendix 8 - Saturday Route Map

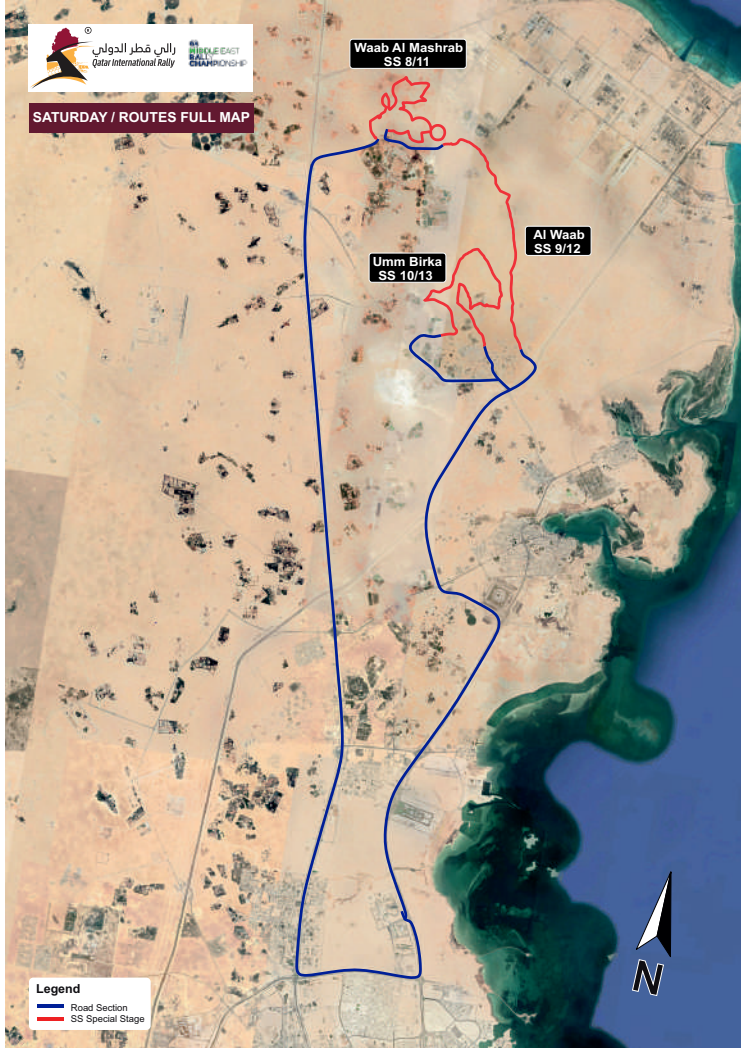

QMMF Media & Media Coverage

QMMF Media Information

All relevant media information and results will be available on the QMMF website please see following link:



<https://qmmf.com/events/2023-qatar-international-rally/>





Media TV Coverage (Live)



Live TV coverage by Al Kass sports channel of the preevent, start finish & prize giving ceremonies in addition daily highlights to be broadcasted live from the rally start.

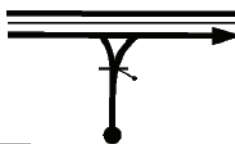
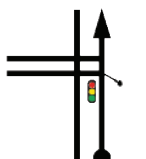
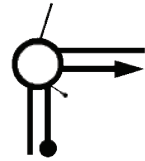

Appendix 9 - Odometer Calibration

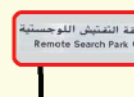
Odometer calibration			DISTANCE:	DAY:
SPECIAL STAGE:			AVERAGE	SECTION
			TIME ALLOWED:	
DISTANCE		DIRECTION	INFORMATION	REGRESS. DISTANCE
TOTAL	PARTIAL			
0,00		 1	N 25° 29.084' E 51° 27.727'	16,69
0,26	0,26	 2		16,43
1,29	1,03	 3		
1,38	0,09	 4	 N 25° 28.771' E 51° 27.029'	
0,00				
1,01	1,01	 5	 N 25° 29.251' E 51° 26.735'	

Odometer calibration

Appendix 9 - Odometer Calibration

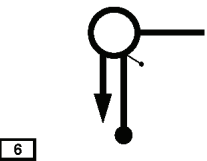
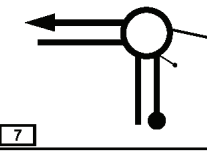
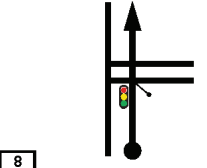
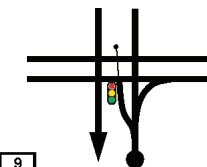
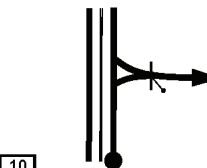
Odometer calibration			DISTANCE:	DAY:	
SPECIAL STAGE:			AVERAGE	SECTION	
			TIME ALLOWED:		
DISTANCE		DIRECTION	INFORMATION		REGRES. DISTANCE
TOTAL	PARTIAL				
1,06	0,05				
2,35	1,29				
3,47	1,12				
3,96	0,49				
4,20	0,24				N 25° 29.084' E 51° 27.727'







Appendix 10 - Al Maha Island (Holding Area)

Lusail Sports Arena		DISTANCE:		DAY:	
Al Maha Island (Holding Area)		16,69 km		SECTION	
SPECIAL STAGE:		AVERAGE		TIME ALLOWED:	
DISTANCE		DIRECTION		INFORMATION	
TOTAL	PARTIAL			REGRESS. DISTANCE	
0,00		 1		TRIP ZERO N 25° 29.084' E 51° 27.727'	16,69
0,26	0,26	 2			16,43
0,76	0,50	 3			15,93
0,92	0,16	 4		<u>Direction</u> Doha (South)	15,77
3,60	2,68	 5		<u>Direction</u> Doha Lusail Central Rawdat Al Hamama	13,09
6,85					

- 1 -



Appendix 10 - Al Maha Island (Holding Area)

Al Maha Island (Holding Area)	Lusail Sports Arena		DISTANCE:		DAY:	
	Al Maha Island (Holding Area)		16,69 km		SECTION	
	SPECIAL STAGE:		AVERAGE		TIME ALLOWED:	
	DISTANCE		DIRECTION		INFORMATION	
TOTAL	PARTIAL					
10,45	6,85			<u>Direction</u> Lusail South Leabaib EXIT 22		6,24
		6				
11,63	1,18			<u>Direction</u> Lusail South Marina District		5,06
		7				
12,57	0,94			<u>Direction</u> Lusail South Marina District		4,12
		8				
12,81	0,24			<u>Direction</u> Entertainment City Marina District		3,88
		9				
13,53	0,72			<u>Direction</u> Place Vendôme Tarfat Lusail Marina		3,16
		10				
1,36						

- 2 -



Appendix 10 - Al Maha Island (Holding Area)

Lusail Sports Arena		DISTANCE:		DAY:	
Al Maha Island (Holding Area)		16,69 km		SECTION	
SPECIAL STAGE:		AVERAGE		TIME ALLOWED:	
DISTANCE		DIRECTION	INFORMATION	REGRESS. DISTANCE	
TOTAL	PARTIAL				
14,89	1,36		<u>Direction</u> Marina	1,80	
15,22	0,33		<u>Direction</u> Al Maha Island Tarfat Lusail Marina Promenade	1,47	
15,39	0,17		<u>Direction</u> Al Maha Island Tarfat Lusail	1,30	
15,57	0,18			1,12	
15,75	0,18			0,94	
0,31					

Al Maha Island (Holding Area)

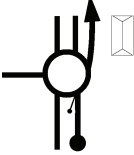
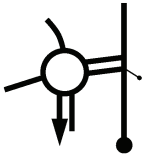
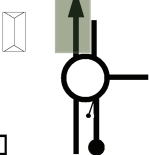

Appendix 10 - Al Maha Island (Holding Area)

Al Maha Island (Holding Area)	Lusail Sports Arena		DISTANCE:	DAY:
	Al Maha Island (Holding Area)		16,69 km	SECTION
	SPECIAL STAGE:		AVERAGE	TIME ALLOWED:
	DISTANCE		DIRECTION	INFORMATION
TOTAL	PARTIAL			
16,06	0,31			0,63
		16		
16,53	0,47			0,16
		17		
16,69	0,16		Holding Area	0,00
		18		



Appendix 11 - Remote Refuelling Access

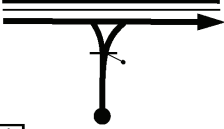
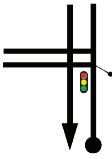
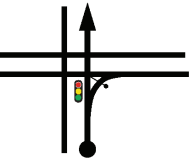
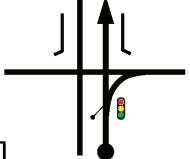
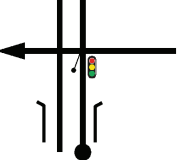





Lusail Sports Arena		Remote Refuelling Access		DISTANCE:	DAY:
				36,14 km	2
SPECIAL STAGE:		AVERAGE		SECTION:	4/5
				TIME ALLOWED:	
DISTANCE		DIRECTION	INFORMATION	REGRESS. DISTANCE	
TOTAL	PARTIAL				
0,00			TRIP ZERO N 25° 29.084' E 51° 27.727'	36,14	
		1			
0,26	0,26			35,88	
		2			
0,76	0,50			35,38	
		3			
0,92	0,16		<u>Direction</u> Al Khor (North)	35,22	
		4			
1,09	0,17		<u>Direction</u> Al Khor	35,05	
		5			
6,33					

Remote Refuelling Access

- 1 -

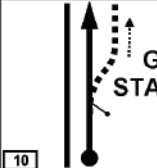

Appendix 11 - Remote Refuelling Access

Remote Refuelling Access		Lusail Sports Arena		DISTANCE:	DAY:
		Remote Refuelling Access		36,14 km	2
SPECIAL STAGE:		AVERAGE		SECTION	TIME ALLOWED:
				4/5	
DISTANCE		DIRECTION		INFORMATION	REGRESS. DISTANCE
TOTAL	PARTIAL				
7,42	6,33	6		<u>Direction</u> Al Thakhira Al Khor Semaisma 	28,72
9,39	1,97	7		<u>Direction</u> Al Thakhira Al Khor Tenbek 	26,75
14,41	5,02	8		<u>Direction</u> Al Thakhira Al Khor Al Bayt Stadium 	21,73
18,43	4,02	9		<u>Direction</u> Al Thakhira Al Khor 	17,71
21,35	2,92	10		 	14,79
		0,94		- 2 -	



Appendix 11 - Remote Refuelling Access

Lusail Sports Arena		DISTANCE:	DAY:	
Remote Refuelling Access		36,14 km	2	
SPECIAL STAGE:		AVERAGE	SECTION	
			4/5	
		TIME ALLOWED:		
DISTANCE		DIRECTION	INFORMATION	REGRESS. DISTANCE
TOTAL	PARTIAL			
22,29	0,94		<p><u>Direction</u></p> <p>Al Thakhira Al Corniche Al Khor Hospital</p>	13,85
23,43	1,14		<p><u>Direction</u></p> <p>Al Thakhira Al Corniche Al Khor Hospital</p>	12,71
24,28	0,85		<p><u>Direction</u></p> <p>Al Thakhira Al Corniche Al Khor Hospital</p>	11,86
25,63	1,35		<p><u>Direction</u></p> <p>Ras Laffan Al Thakhira</p>	10,51
28,40	2,77		<p><u>Direction</u></p> <p>Ras Laffan Umm Berkah</p>	7,74
1,31				

- 3 -

Appendix 11 - Remote Refuelling Access

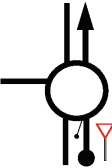
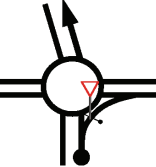
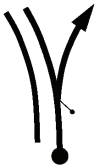
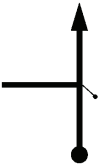
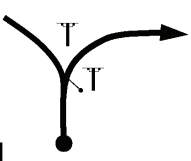
Remote Refuelling Access		Lusail Sports Arena		DISTANCE:	DAY:
		Remote Refuelling Access		36,14 km	2
SPECIAL STAGE:		AVERAGE		SECTION	TIME ALLOWED:
				4/5	
DISTANCE		DIRECTION		INFORMATION	REGRESS. DISTANCE
TOTAL	PARTIAL				
29,71	1,31		<i>Direction</i> Al Shamal Road Ras Laffan Umm Birka	6,43	
34,06	4,35		<i>Direction</i> Al Shamal Road Simsima	2,08	
34,78	0,72		<i>Direction</i> Umm Al Qahab	1,36	
35,07	0,29			1,07	
35,74	0,67			0,40	
0,14					

- 4 -



Appendix 11 - Remote Refuelling Access

Lusail Sports Arena		DISTANCE:	DAY:	
Remote Refuelling Access		36,14 km	2	
SPECIAL STAGE:		AVERAGE	SECTION	
			4/5	
		TIME ALLOWED:		
DISTANCE		DIRECTION	INFORMATION	REGRESS. DISTANCE
TOTAL	PARTIAL			
35,88	0,14			0,26
36,14	0,26			0,00

Remote Refuelling Access



SERVICE PARK FACILITIES ORDER & SERVICE AREA REQUEST FORM

CONTACT DETAILS	
Competitor	
Crew 1	
Crew 2 (if applicable)	
Name of contact person	
On-event mobile nr	
E-mail address	

SERVICE PARK FACILITIES		
Standard service area	10 x 10 m (1 car) / 20 x 10 m (2 cars)	
Please mark, if required (1)	Price	Quantity
Additional service space (each 5 x 10 m) (2)	2000 QAR	
Personal toilet	Upon agreement	
Additional security	Upon agreement	
Other facilities	Please contact Service Park Coordinator (Pierre QMMF email)	

REQUEST FOR CONSECUTIVE SERVICE AREAS	
If you require the service areas of 2 or more cars to be located together, please list all crews below	
Crew 1	
Crew 2	
Crew 3	
Crew 4	

INVOICE DETAILS (Company name, address, VAT number, contact person)

The complete Service Park Facilities Order form must be sent to the Organiser's e-mail ([Pierre QMMF email](#)) by Monday, 6th February at 17.00h the latest (art. 3 of Supplementary Regulations).

- (1) The supply of the above-mentioned facilities / services is limited. The Organiser may not be able to provide you the requested quantities. The Service Park Coordinator will contact you for further details. Invoice for requested services will only be issued after the Service Park Coordinator has confirmation.
- (2) Maximum depth of the service area is 10 m.

Requested by:	
Signature	Date
Name	



RECONNAISSANCE REGISTRATION FORM

CONTACT DETAILS	
Car no	
Competitor	
Driver's name	
Driver's mobile no	
Co-Driver's name	
Co-Driver's mobile no	

RECONNAISSANCE CAR DETAILS	
Make	
Model	
Plate no.	
Insurance (Company / Police no)	

RECONNAISSANCE REGISTRATION	
<p>Reconnaissance registration and administrative checks will take place at QMMF office on Tuesday, 14th February, from 16.00h. The crew must register in person. A detailed schedule will be issued by means of a bulletin. Any delay on the presentation will result in a penalty laid down in art. 10 of Supplementary Regulations.</p>	
<p>Documents to be presented:</p> <ul style="list-style-type: none"> • This form duly filled in • Competitor's license • Driver's and Co-driver's competition licenses • Driver's and Co-driver's valid driving licenses • Driver's and Co-driver's ID cards / passports • ASN authorization for all foreign competitors and/or drivers • Car registration papers • Car insurance cover certificate • Car owner authorization to participate in the rally (if not one of the crew members) 	
<p>The reconnaissance car must be equipped with a speed control checking device that will be delivered to the crew following reconnaissance registration.</p>	

RECONNAISSANCE REGULATIONS	
<p>Please see:</p> <ul style="list-style-type: none"> • Art. 35 & 34.2 of 2023 FIA Regional Rally Sporting Regulations • Art. 9 and Appendix 2 of Supplementary Regulations 	

SIGNATURES	
Driver	
Co-Driver	

ON-BOARD CAMERA REQUEST FORM

CONTACT DETAILS	
Car no	
Competitor's name	
Crew	
Competitor's address	
E-mail address	

USE OF FOOTAGE

CAMERA DETAILS	
Make	
Model	
Make	
Model	

EXCERPT OF 2023 FIA REGIONAL RALLY SPORTING REGULATIONS
<p>18.1 ON-BOARD CAMERAS (...)</p> <p>18.1.2 The competitor of any car which carries an on-board camera must have the prior agreement of the organiser or Championship Promoter (if any). Authorised cameras will be identified by an adhesive decal and must be mounted in the car at the time of scrutineering.</p> <p>18.1.3 Competitors wishing to use a camera must supply the following information to the organiser or Championship Promoter (if any) at least one week before the start of reconnaissance: competitor's name, car number, competitor's address, use of footage and brand and model name of the device(s) used. (...)</p>

The complete On-board Camera Request form must be sent to the Organiser's e-mail (Angelene's email) by Wednesday, 8th February at 17.00h the latest.

Requested by:	
Signature	Date
Name	



AUTHORISATION FORM

COMPETITOR IDENTIFICATION	
Car no	
Competitor's name	
Crew	

AUTHORISATION	
I hereby authorise the person named below to represent me and sign on my behalf in all matters related to my participation in 2023 Qatar International Rally.	
Authorised Person's Name	
Identification / Passport No	
Email address	
Mobile Number	

AUTHORISED BY		
Competitor's signature		Date
Driver's signature		Date
Co-Driver's signature		Date



Ruler's State of Qatar

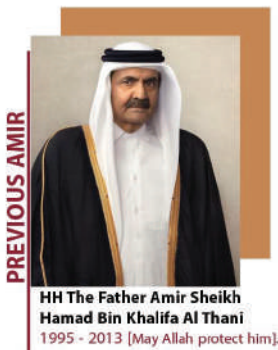



رالي قطر الدولي
Qatar International Rally



الاتحاد القطري للسيارات والدراجات النارية
QATAR MOTOR & MOTORCYCLE FEDERATION

Useful Fact About Qatar

General Information

Country Full Name:	State of Qatar
Capital City:	Doha
Language:	Arabic - English
Religion:	Islamic
Time Zone:	GMT + 3 Hours
Dialing Code:	+974
Weights & Measures:	Metric
Electricity:	220v + 6% with frequency of 50 Hertz
Population:	2,684,329 estimated population, December 2020



National Day & Official Logo

December 18, celebrated every year to commemorate the founding of State of Qatar by Sheikh Jassim Bin Mohammad Al-Thani [The Founder].

Geographical Location

Qatar located in the Middle East, it is a small peninsula in the east of Arabia which located in the Arabian Gulf, and shares a land borders with the Kingdom of Saudi Arabia to the south-west and is surrounded by the Arabian sea. The Global Peace Index ranks features Qatar as one of 30 most peaceful countries in the world, and the most peaceful in the MENA region.

- **Land Area:** 11,400 Square Kilometers.

Qatar Climate / Weather

Summer lasts from May to September, and temperatures at that time generally average 35°C (95°F), although it can get up to 50°C (122°F). The autumn/ winter months (November-April) are much milder with pleasant, cool evenings.

Average High/Low Temperature for Doha, Qatar

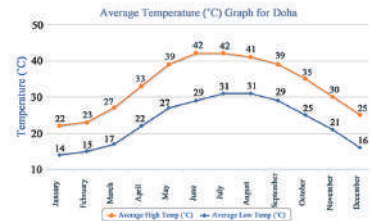

Qatar Culture Awareness

Please Do

- 1- Dress modestly. Qatar is a Muslim country and it has conservative dress codes. Trousers are acceptable for women but avoid shorts, strappy low cut tops, see through and transparent clothes.
- 2- Use Mowasalat turquoise taxis as they are safe and clean, and the majority of the drivers speak English.
- 3- Drink plenty of water, especially during the hot summer. Two liters of water per person, per day is the absolute minimum that should be drank.
- 4- Use a high factor sun block on all exposed skin, even in the winter, including the tops of your feet if wearing sandals. It is highly recommended to wear hats or caps.
- 5- Remember the air conditioning, which can chill you at restaurants, cinemas and shopping malls. Take always along a light jacket as a precaution.

Please Do Not

- 1- Take a photograph without permission of other people, including police and armed forces, or sensitive sites. Arabic women and many older people strongly object to being photographed.
- 2- Drink too much that your behavior is affected in public. Alcohol in Qatar is strictly regulated concession and there is zero tolerance for drunk driving, rowdy behavior and drugs.
- 3- Display affection in public between men and women as if deemed to infringe moral values, individuals may be prosecuted.

Driving Rules in Qatar



Once you get into an accident please call 999, and wait for the traffic police to come so that you can get an Incident report.



Speeding fine goes up to 6,000/- QRs & further actions will be taken by authorities depending on the violation/s.



Be careful in speeding & parking as radars are available everywhere in Doha (Qatar).



If you pass through Red light the fine is 1 month in jail!

For more information please visit on the below website: <https://qatarofw.com/driving-violations-and-fines/>



رالي قطر الدولي
Qatar International Rally



الاتحاد القطري للسيارات والدراجات النارية
QATAR MOTOR & MOTORCYCLE FEDERATION

Medical & Safety Service

Qatar Departments Emergency Numbers



Department Name:
Police Department
Telephone:
999



Department Name:
Fire Department
Telephone:
999



Department Name:
Ambulance Department
Telephone:
999

Hospital in the Area



Hospital Name:
Umm Slal Health Center
Telephone:
+974 4027 3777



Hospital Name:
Al Kharitiyyat Medical
Telephone:
+974 4493 5117



Hospital Name:
Peace Medical Center
Telephone:
+974 4444 1525

Pharmacies



Pharmacy Name:
Kulud Pharmacy
Telephone:
+974 4487 7784



Pharmacy Name:
Afiya Pharmacy
Telephone:
+974 4472 3356



Pharmacy Name:
Sunlife Pharmacy
Telephone:
+974 4421 6981

Towing Services



Towing Service Name:
A A Roadside Assistance
Telephone:
+974 4444 9945



Towing Service Name:
Arabian Automobile Association
Telephone:
+974 4481 0400



Towing Service Name:
Qatar Car Towing
Telephone:
+974 3104 1144

Network & Transportation Services

Mobile Network Servies



There are only 2 mobile network providers in the State of Qatar. Which is Ooredoo and Vodafone. Amongst these to network providers Ooredoo is capable of providing 5g Internet services

Car Rental Companies



Company Name:
Abdullah Abdulghani & Brother's
Telephone:
+974 4431 4469



Company Name:
Al Muftah Rent-a-Car
Telephone:
+974 4442 6649



Company Name:
Avis
Telephone:
+974 4466 7744



Company Name:
Doha Rent-a-Car
Telephone:
+974 4435 4577



Company Name:
Hertz
Telephone:
+974 4462 2891



Company Name:
National Car Rental
Telephone:
+974 4474 0666

Airline Companies



Airline Name:
Qatar Airways
Telephone:
+974 4449 6666



Airline Name:
Oman Air
Telephone:
+974 4432 0509



Airline Name:
Royal Jordanian
Telephone:
+974 4443 1431



Airline Name:
Air France
Telephone:
+974 4432 1208



Airline Name:
British Airways
Telephone:
+974 4432 1434



Airline Name:
American Airlines
Telephone:
+974 4499 5737



Airline Name:
KLM
Telephone:
+974 4432 1208



Import of Vehicles, Spare Parts & Shipping

National laws

Please note that it is **NOT** allowed to ship the good in the following given links:

Doha Hamad Airport, shipping restrictions

<https://dohahamadairport.com/airport-guide/at-the-airport/security-customs>

Quick access (Scan QR Code)



Customs clearance

Documents Required:







- 1- Packing list.
- 2- Commercial Invoice (Consigned to Qatar Motor & Motorcycle Federation).
- 3- Airway Bill or Bill of Lading (Consigned to Qatar Motor & Motorcycle Federation).

Shipping Procedure:

- 1- All vehicles will be shipped as Non Hazardous Cargo.
(Fuel tank must be empty and battery disconnected).
- 2- Shipper of the goods must provide a full set of documentation for all items for customs purposes.
- 3- Your goods are not insured, Logistics Companies not responsible for damages and missing items.

Import of Vehicles, Spare Parts & Shipping

National laws

-  -Fuel tanks, engines and all parts making contact with fuel must be emptied and drained as much as possible in order to avoid any risk of fuel and gas leak.
-  -Fuel is considered Dangerous Goods and cannot be shipped in container or airplane.
-  -Oil is not considered Hazardous Goods. As for the paperwork in Qatar we cannot use ATA carnet, so it is required to issue a Commercial Invoice & Packing list.
-  -All batteries must be disconnected and insulated.
-  -Please do not send any sprays/aerosols along with the cars & parts as these are considered Dangerous/Hazardous Goods and will cause problems with local authorities.
-  -We can provide a combined transport for shipping all these items and carpets/floor tiles, ahead by sea freight to keep cost at a minimum and provide an alternative solution.
-  -Also please do not send any other fluids such as contact cleaner, acetone, brake cleaner etc.



The agent

Carson Logistics is the official Logistics partner for QIR 2021. Carson Logistics is a company specialized in handling all logistics requirements required for Manateq International Rally of Qatar. With their extensive knowledge & Experience in handling any kind of activities which are time sensitive & require safe operations. With claiming experience in handling shipments from all over the world to deliver in Doha. The company inherits years of local & international expertise which makes them the ideal company to handle these operations along with their overseas partners who share the same enthusiasm. Carson Logistics will handle all Customs procedure & shipment Clearance that is required in Qatar.



رالي قطر الدولي
Qatar International Rally



الاتحاد القطري للسيارات والدراجات النارية
QATAR MOTOR & MOTORCYCLE FEDERATION

Carson Logistics Contact & Bank Details

Company contact details

Operations Manager



Leo Arul



+974 3314 4400



leo@carsonlogistics.net

Projects Manager



Sanjeev Menon



+974 3386 7168



sales@carsonlogistics.net

Bank details

Qatar Riyals Bank is

Bank Name - Commercial Bank of Qatar (D' Ring Road Branch)

Beneficiary - Carson Logistics W.L.L

QRS A/c No. - 4700-284786-001

IBAN - QA59CBQA000000004700284786001

Swift Code - CBQAQAQA

US Dollars Bank is

Bank Name - Commercial Bank of Qatar (D' Ring Road Branch)

Beneficiary - Carson Logistics W.L.L

USD A/c No. - 4700-284786-051

IBAN - QA67CBQA000000004700284786051

Swift Code - CBQAQAQA



Hospitality, Accommodation & Hotels

Hospitality arrangements

Contact Person



Servin K.V - QMMF



+974 3326 6985 | +974 7763 3430 | +974 4437 9751



sarvin.kv@qmmf.com.qa

Accommodation & Hotels

For more details please contact



Angelene Lapuz - QMMF

« To check availability and special rates »



angelene.lapuz@qmmf.com.qa

Accommodation

QMMF will provide 5 nights Stay in a twin bedded room in Retaj Al Rayyan hotel for the competing Driver & Co-Driver.

NOTE: NO EXTRA NIGHT EARLY CHECK IN OR LATE CHECKOUT WIL BE PROVIDED.

Retaj Al Rayyan Hotel Contact Details



Dafna, Diplomatic District,

P.O. Box 25556

Doha, Qatar



+974 4420 44 44



www.retajalrayyan.com



RETAJ
فندق الريان
AL RAYYAN HOTEL





رالي قطر الدولي
Qatar International Rally



Hospitality, Accommodation & Hotels

List of recommended hotels



Intercontinental Doha

Telephone: +974 4484 4444

Website:

www.intercontinental.com



Intercontinental Doha - The City

Telephone: +974 4015 8888

Website:

www.intercontinental.com



Ritz Carlton

Telephone: +974 4484 8000

Website:

www.ritzcarlton.com



Fraser Suites Doha

Telephone: +974 4424 3444

Website:

www.frasershospitality.com



Century Hotel

Telephone: +974 4445 5111

Website:

www.centuryhoteldoha.com

Appendix 12 - Travel Way from the Airport to LCSC

Hamad Airport - Losail Circuit Sports Club (LCSC)

